



IRRIGATION
POWERTRAIN

UNIVERSAL MOTION COMPONENTS CO., INC.

Driving Innovation Since 1978

UMC CX COUPLER INSTALLATION MANUAL

- New Irrigation Machines:

1. Remove the three bolts and nuts as well as the drive shaft saddle mount that were pre-installed on the UMC CX Coupler as shown in the picture. Save all of the components for later installation.
2. Install the CX Couplers onto UMC Gearbox and UMC PowerSaver Center Drive. Align the slot on the CX Coupler with the through hole on either the gearbox or the center drive's shaft. Insert the bolt and tighten the nut to 35 ft-lbs. of torque. **DO NOT OVER-TIGHTEN.**

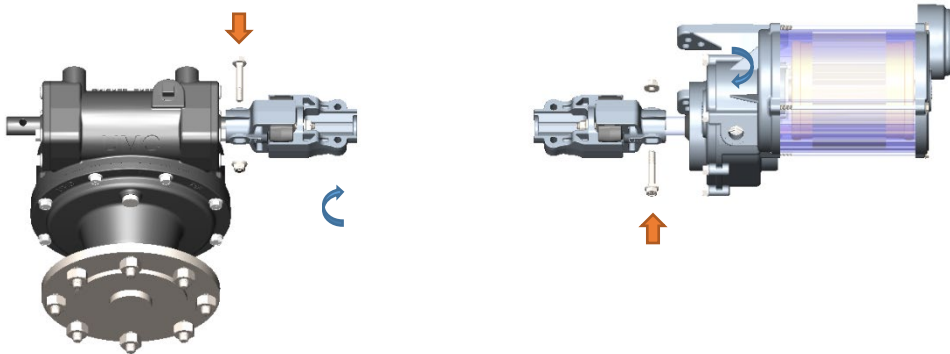
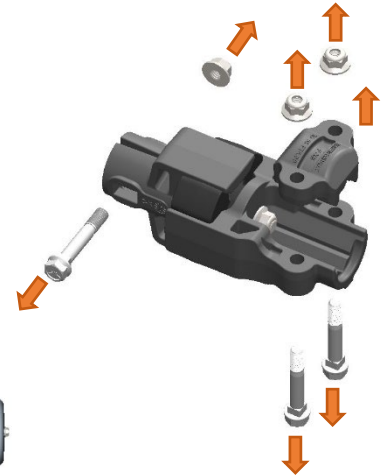

3. Before installing the drive shaft, align the CX Couplers axially by rotating the already installed coupler on the center drive's side. Once aligned, install the square shaft onto the two couplers in one of the two shaft configurations shown. **Center the shaft for even gaps on both ends.**

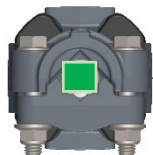

Configuration 1:
If using 0.75 inch
square drive shaft.

or



Configuration 2:
If using 0.875 to 1 inch
square drive shaft

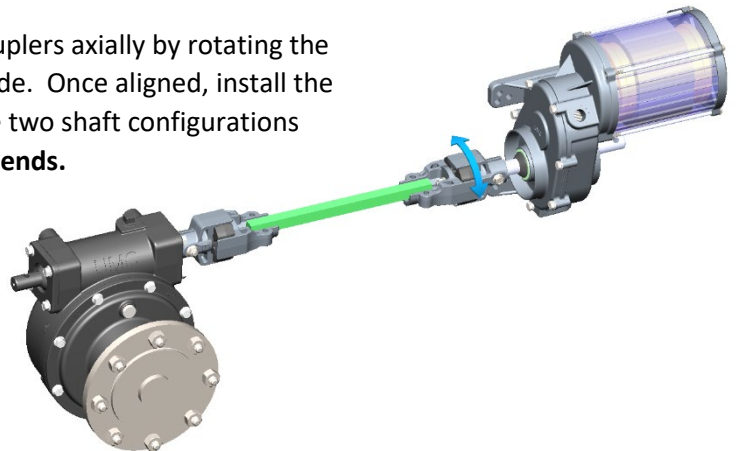

4. Once the drive shaft is in place, re-install the saddle mount and insert the two bolts. Tighten the two nuts in an **ALTERNATING FASHION, one full turn at a time to avoid damaging the Saddle Mount.** Tighten to 35 ft-lbs. of torque. **DO NOT OVER-TIGHTEN.**

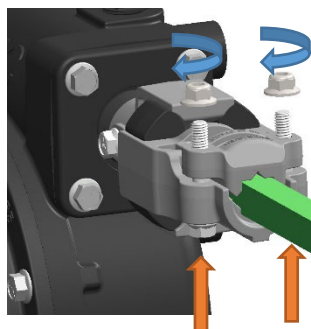

The illustration shown is using a 0.75 inch square shaft (configuration 1) as an example.



UNIVERSAL MOTION COMPONENTS CO., INC.

Driving Innovation Since 1978

UMC CX COUPLER INSTALLATION MANUAL

- Retrofitting Existing Irrigation Machines:
 1. After the installation of either a new gearbox, PowerSaver center drive or both, you are now ready to connect the power transmission system. Refer to installation steps 1 and 2 in the “New Irrigation Machines” section on page 1.
 2. Measure the length, shown below, between the two CX Couplers. Cut the drive shaft to the “measured length” less 1.25 inches. (note: subtracting 1.25 inches from the total length is to compensate for the spaces taken up by the bolt and nut inside the drive shaft housing area, circled in figure below.)

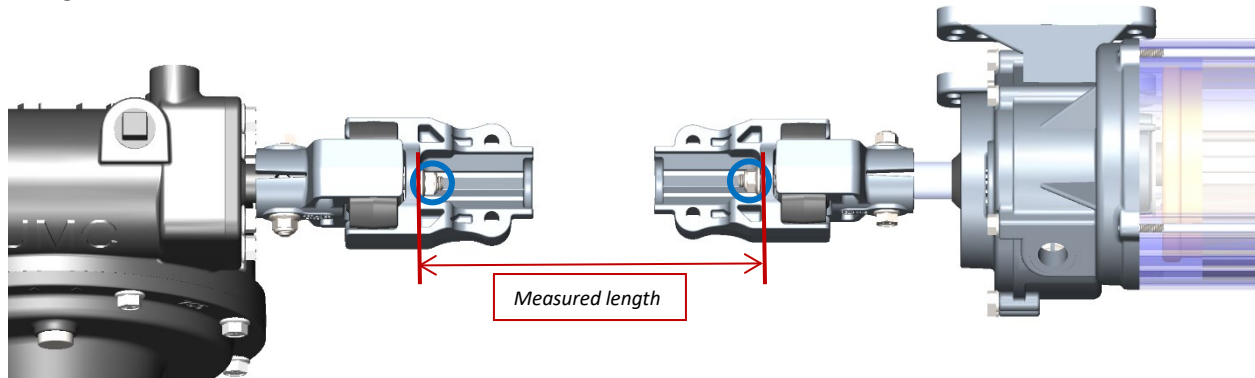

For example:

if measured length is 3 feet and 5 inches, then the drive shaft should be cut to

$$3'5'' - 1.25'' = 3'3.75''$$

3 feet and 3 & 3/4 inches long.

3. Once the square drive shaft is cut, follow steps 3 and 4 in the “Brand New Irrigation Machine” section on page 1 to complete the power transmission system installation.