

Quality Irrigation Products



ISO 9001:2015
Certified
Quality Management



ANSI National Accreditation Board
ACCREDITED
ISO/IEC 17021-1
MANAGEMENT SYSTEMS
CERTIFICATION BODY

UMC is a ISO 9001:2015
Certified Company



IRRIGATION
POWERTRAIN

www.umcproducts.com

2920 Airway Ave, Costa Mesa, Ca. 92626
phone: 714.437.9600 fax: 714.437.9700

Final Drive Gearbox



Features and Benefits

The patented UMC® 765-U-AD™ gearbox is our largest and most durable high performance gearbox with a 50:1 gear ratio. It is a direct replacement for its predecessor, the 760-U™, and features several improvements that enhance load capacity, gear life and seal life.

- ▶ 2.50" diameter steel output shaft
- ▶ 50:1 gear ratio
- ▶ Cartridge input and output seals
- ▶ Patented Vented Internal Diaphragm with large expansion cavity for near zero psi pressure accumulation which increases seal life and reduces oil leaks
- ▶ 16-Bolt mounting pattern

765-U-AD™ Gearbox

Designed for heavy spans, extreme conditions, corner systems, and lateral / linear carts

The UMC® 765-U-AD™ gearbox is designed for use on center pivots and lateral / linear irrigation systems. It is typically used for the most extreme conditions and applications such as corner systems, lateral carts and heavy towers. It is the ideal choice for areas where extreme field conditions exist and/or machines run high annual hours of operation.

| Part Number | Ratio |
|-------------|-------|
| 10162-105A | 50:1 |

- ▶ Enhanced gear material that increases load capacity, reduces gear wear and lowers operating temperatures, extending gear life
- ▶ External seal protectors for input and output seals
- ▶ Largest output bearings in the industry
- ▶ Dual ended input shaft with hub cap for the unused end
- ▶ Large 3/4" oil fill and drain plugs for easier maintenance
- ▶ Filled with extreme pressure gear oil
- ▶ Extra long carriage bolts
- ▶ Allow use with reinforced rims
- ▶ Positive wheel register
- ▶ Bronze gear optional
- ▶ This gearbox features UMC's registered Four-Rib Design® trademark

sales@umcproducts.com

Universal Motion Components®

Dimensional Drawing

765-U-AD™ Final Drive Gearbox

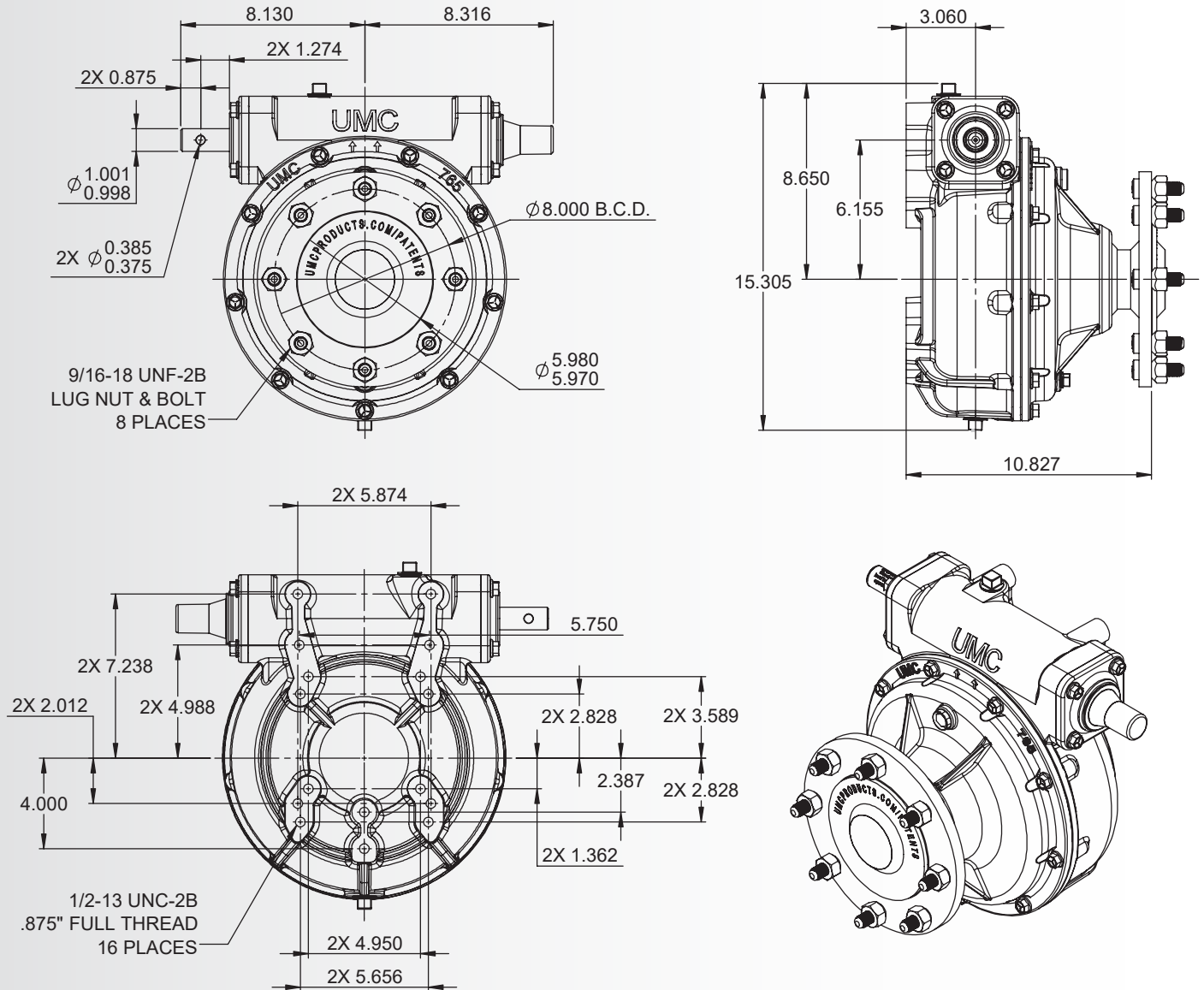

Gearboxes with UMC's registered Four-Rib Design® trademark are a distinct design feature signaling a genuine UMC irrigation product. Learn other ways to identify genuine UMC Irrigation hardware, at www.umcproducts.com/genuine.

UNIVERSAL
MOTION
COMPONENTS



www.umcproducts.com

sales@umcproducts.com

Universal Motion Components, Co. Inc.
2920 Airway Ave, Costa Mesa, Ca. 92626
Phone - 714-437-9600 Fax - 714-437-9700
Web - <http://www.umcproducts.com>
E-mail - sales@umcproducts.com