

## Quality Irrigation Products



ISO 9001:2015  
Certified  
Quality Management



UMC is a ISO 9001:2015  
Certified Company



IRRIGATION  
POWERTRAIN

www.umcproducts.com

2920 Airway Ave, Costa Mesa, Ca. 92626  
phone: 714.437.9600 fax: 714.437.9700

## Booster Pump



## 130GPM 60Hz Booster Pump - Flanged

Designed specifically for mechanized irrigation

The UMC 130GPM 60Hz Booster Pump is purpose built for use on center pivots and lateral / linear irrigation systems and is designed to boost line pressure for a pivot's end gun.

Part Number	Description
06168-184F	130GPM-60Hz-Flanged BP-SS Impeller
06168-184B	130GPM-60Hz-Flanged BP-Iron Impeller

## Features and Benefits

The UMC 130 GPM 60Hz Booster Pump is designed with features that enhance performance and reduce failures.

- ▶ Rated Flow: 0-132GPM
- ▶ Rated Boost Pressure: 33 PSI @ 132GPM
- ▶ Premium Efficient TEFC 2HP (1.5SF) motor
- ▶ CSA, CE, US DOE & NRCAN certified motor
- ▶ IP45 rated motor
- ▶ Extruded aluminum stator can for superior heat dissipation and corrosion resistance
- ▶ Stainless steel fan shroud and stator canopy for superior protection and corrosion resistance
- ▶ Stainless stator bolts for enhanced corrosion resistance
- ▶ Motor drain holes eliminate moisture accumulation

- ▶ Stainless steel spray guard protects motor drain holes from water intrusion
- ▶ Automatic reset thermal protector
- ▶ Die cast aluminum junction box with threaded NPT cable gland connection
- ▶ Cast iron volute with threaded NPT and flanged connections: 2.5" x flanged suction and 2" x flanged discharge
- ▶ Stainless steel wear ring for volute suction
- ▶ Precision balanced impeller
- ▶ Stainless steel or iron impeller options
- ▶ Stainless steel rotor shaft
- ▶ Mechanical shaft seal
- ▶ Drain plug in volute for easy after season draining
- ▶ Stainless steel hardware on pump and motor
- ▶ Back pull out pump design
- ▶ Vertical mount configuration

[sales@umcproducts.com](mailto:sales@umcproducts.com)

# Universal Motion Components®

Dimensional Drawing

## 130GPM 60Hz Booster Pump - Flanged

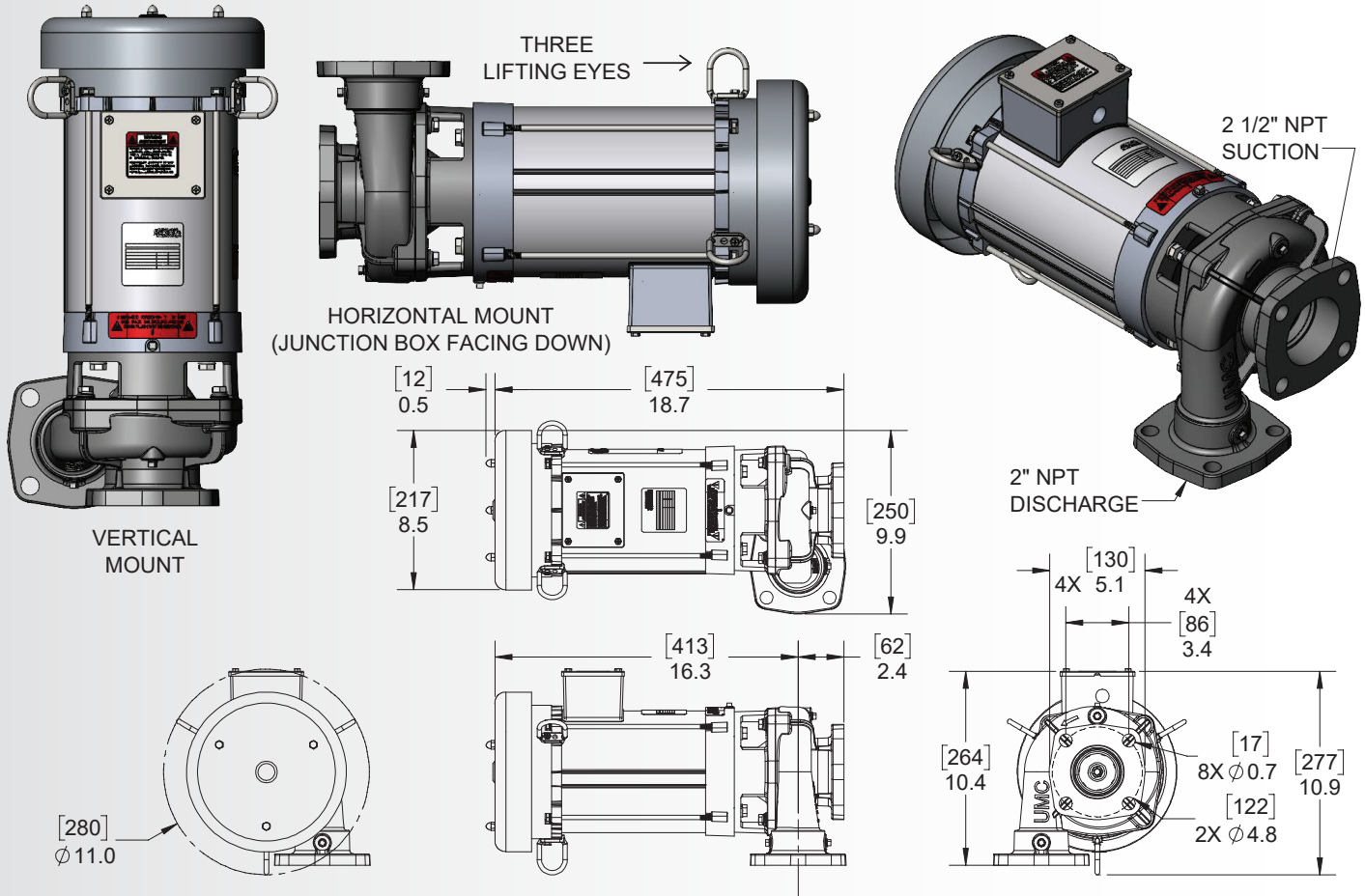

UMC 130GPM 60Hz Booster Pump Performance - 3465 RPM					
Flow		Boost Pressure		Current & Power	
USGPM	m3/h	PSI	TDH (m)	Amps (460V)	Power (HP)
0	0	33	23	1.9	1.3
22	5	34	24	2.2	1.5
44	10	35	24	2.4	1.8
66	15	35	25	2.6	2.1
88	20	35	25	3.0	2.4
110	25	35	25	3.1	2.6
132	30	33	23	3.4	2.9
154	35	31	22	3.7	3.1

UNIVERSAL  
MOTION  
COMPONENTS



[www.umcproducts.com](http://www.umcproducts.com)



[sales@umcproducts.com](mailto:sales@umcproducts.com)

Universal Motion Components, Co. Inc.  
2920 Airway Ave, Costa Mesa, Ca. 92626  
Phone - 714-437-9600 Fax - 714-437-9700  
Web - <http://www.umcproducts.com>  
E-mail - [sales@umcproducts.com](mailto:sales@umcproducts.com)