

Quality Irrigation Products



ISO 9001:2015
Certified
Quality Management



ANSI National Accreditation Board
ACCREDITED
ISO/IEC 17021
MANAGEMENT SYSTEMS
CERTIFICATION BODY

UMC is a ISO 9001:2015
Certified Company



IRRIGATION
POWERTRAIN

www.umcproducts.com

2920 Airway Ave, Costa Mesa, Ca. 92626
phone: 714.437.9600 fax: 714.437.9700

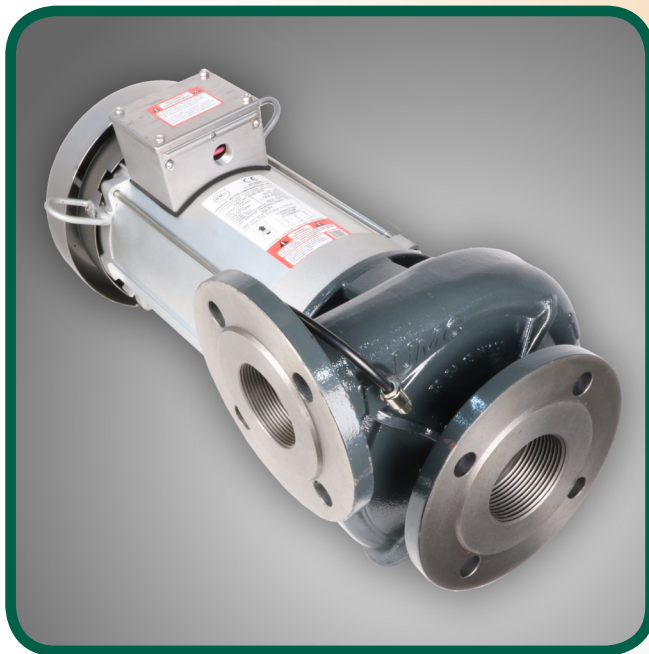

Booster Pump

130GPM 50Hz Booster Pump

Designed specifically for mechanized irrigation

The UMC 130GPM 50Hz Booster Pump is purpose built for use on center pivots and lateral / linear irrigation systems with 50Hz power supply and is designed to boost line pressure for a pivot's end gun.

Model Number	Output RPM
06168-196A	130GPM-50Hz-BP-SS Impeller
06168-261B	BSP Companion Flange Kit
06168-261A	PN16 RF Connection Kit

Features and Benefits

The UMC 130 GPM 50Hz Booster Pump is designed with features that enhance performance and reduce failures.

- ▶ Rated Flow: 0-132GPM (0-30m³/h)
- ▶ Rated Boost Pressure: 34 PSI @ 132GPM
- ▶ IE3 TEFC 2.2kW (1.36SF) motor
- ▶ CE certified motor
- ▶ IP45 rated motor
- ▶ Extruded aluminum stator can for superior heat dissipation and corrosion resistance
- ▶ Stainless steel fan shroud and stator canopy for superior protection and corrosion resistance
- ▶ Stainless stator bolts for enhanced corrosion resistance
- ▶ Motor drain holes eliminate moisture accumulation
- ▶ Stainless steel spray guard protects motor drain holes from water intrusion

- ▶ Automatic reset thermal protector
- ▶ Die cast aluminum junction box with threaded NPT cable gland connection
- ▶ Cast iron volute with threaded NPT and flanged PN16 connections: 2.5" NPT x PN16 suction and 2" NPT x PN16 discharge
- ▶ BSP companion flange kit available
- ▶ Precision balanced investment cast stainless steel impeller
- ▶ Stainless steel rotor shaft
- ▶ Mechanical shaft seal
- ▶ Drain plug in volute for easy after season draining
- ▶ Stainless steel hardware on pump and motor
- ▶ Back pull out pump design
- ▶ Antisiphon tube reduces pump air locking
- ▶ Vertical mount configuration
- ▶ Triple lifting eyes for after installation

sales@umcproducts.com

Universal Motion Components®

Dimensional Drawing

130GPM 50Hz Booster Pump

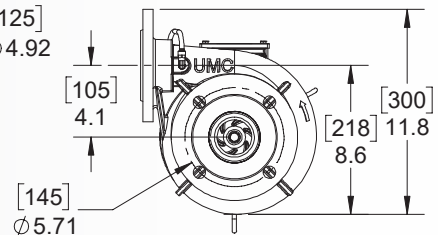
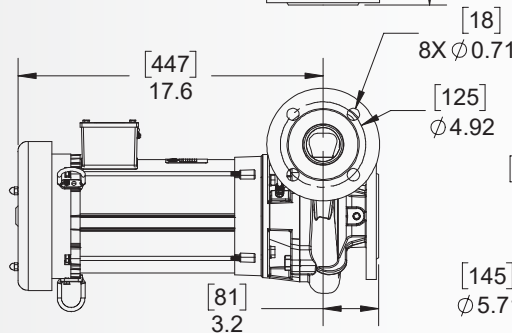
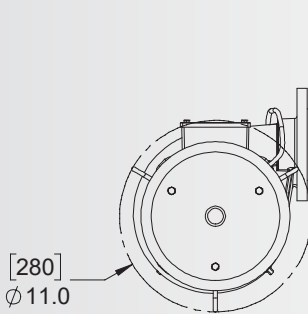
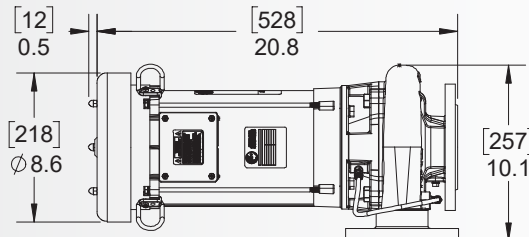
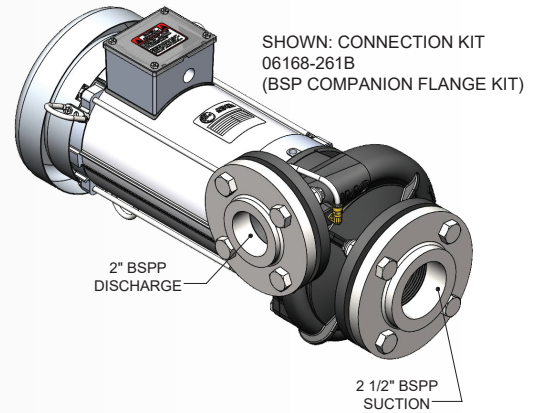
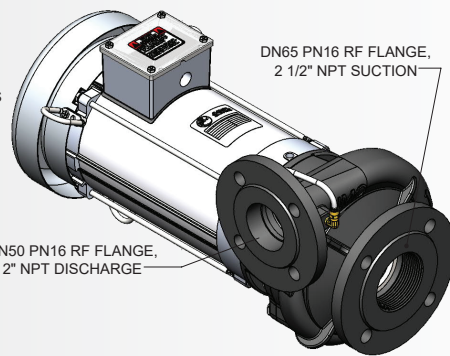
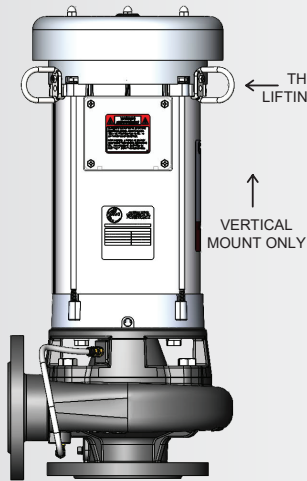

UMC 130GPM 50Hz Booster Pump Performance - 2900 RPM

Flow		Boost Pressure		Current & Power	
USGPM	m3/h	PSI	TDH (m)	Amps (380V)	Power (kw)
0	0	35	25	3.0	1.1
22	5	36	25	3.3	1.3
44	10	36	26	3.6	1.6
66	15	36	26	3.9	1.8
88	20	36	25	4.4	2.1
110	25	35	25	4.9	2.4
132	30	34	24	5.3	2.6
154	35	32	23	5.6	2.8
176	40	29	21	6.0	3.0

UNIVERSAL
MOTION
COMPONENTS



www.umcproducts.com



sales@umcproducts.com

Universal Motion Components, Co. Inc.
2920 Airway Ave, Costa Mesa, Ca. 92626
Phone - 714-437-9600 Fax - 714-437-9700
Web - <http://www.umcproducts.com>
E-mail - sales@umcproducts.com